



# Hayward Gordon

Pumps • Mixers • Strainers

Engineered Systems and Controls

## CHOPX SERIES CHOPPER PUMPS

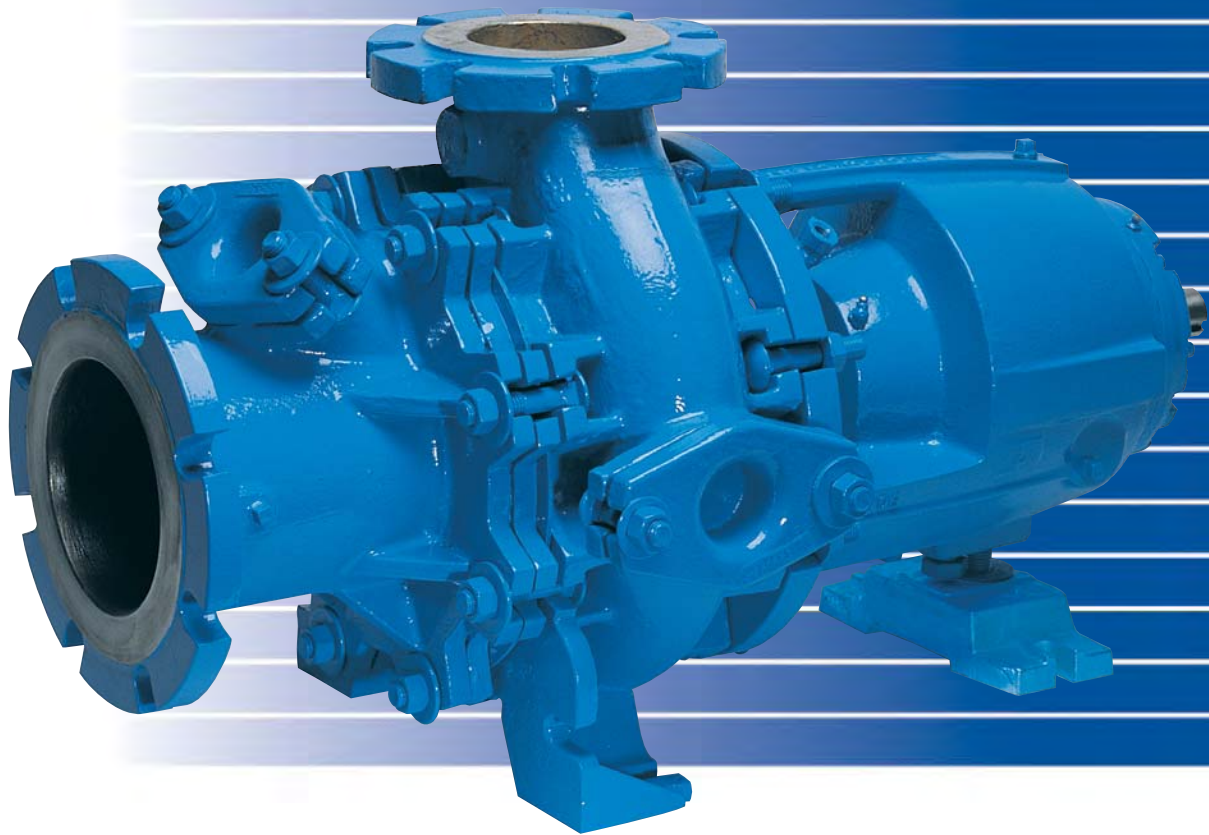

**For solids handling  
requiring combined chopping  
and pumping.**

[www.haywardgordon.com](http://www.haywardgordon.com)

**PUMPS**



For over 45 years, Hayward Gordon has worked closely with our customers to develop exceptional products and tailored process pumping solutions. From our Screw Centrifugal Series, through our hard metal Recessed Impeller Line, to our CHOPX Chopper Pumps, Hayward Gordon's wide range of Solids Handling Pumps tackle the most severe to the most delicate of applications. Put Hayward Gordon's products and experience to work for you. We'll solve your most challenging solids handling pumping problems.

The CHOPX Chopper Series complements this full range of Solids Handling Pumps. Featuring our unique, high efficiency anti-fouling chopping impeller, they simultaneously chop and pump the most difficult solids, eliminating the need for grinders and comminutors. Read on to find out more about this rugged member of our product range.



## INTRODUCTION

CHOPX Series Chopper Pumps perform the dual function of cutting and pumping making them ideally suited for applications requiring reduction of solids size and/or protection of downstream equipment.

The proven clamp type construction, common to all Hayward Gordon centrifugal solids handling pumps, permits the entire wet-end to be manufactured in wear-resistant hard metals to ensure maximum component life in abrasive services.

The major performance benefits of the CHOPX design are summarized below:

- Dual function — pumping and cutting
- Solids reduction and blending
- Anti-Fouling Design
- High efficiency
- Abrasion resistant construction
- Corrosion resistant materials





## OPTIONS & ACCESSORIES

### RECIRCULATING NOZZLES

Where floating or settled solids need to be mixed before pump-out from a pit, a recirculating valve and nozzle assembly can be added to several of the vertical wet-pit and submersible chopper pump configurations. Within digesters, vertical chopper pumps with recirculating nozzles are used to break up scum blankets to improve digester performance. Nozzle head positions can be manually or automatically adjusted from outside the tank. Assemblies supplied with diverter valves can operate with full, partial, or no recirculation.

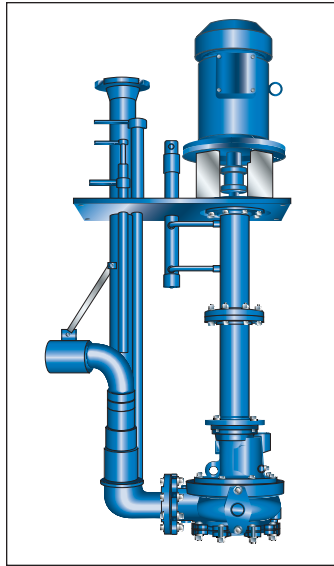

### CONTROL PANELS & FLOAT SWITCHES

Custom controls can be supplied to accommodate various operational requirements. Options include liquid level control, duplex pump controls, and variable frequency drives. A range of alarms, indicators, and mercury float switches is also available for monitoring such things as high temperature, low oil, seal leakage, and liquid level.

### TYPICAL APPLICATIONS

#### Waste Treatment

- scum pits
- difficult lift station services (prisons, hospitals, other public facilities)
- digester recirculation
- digester scum blankets

#### Pulp & Paper

- wood yard & processing plant sumps
- chip & bark handling

#### Food Processing & Rendering

- fruit & vegetable waste
- beef, poultry, and seafood waste parts
- fleshings, hide, bones, fat

#### Miscellaneous

- latex skins
- plastics
- paint sludges
- detergent cakes
- lagoon cleaning



# CHOPX SERIES CHOPPER PUMPS

## FEATURES AND BENEFITS - *The CHOPX Advantages in Detail*

### 1. Dual Function — Pumping & Cutting

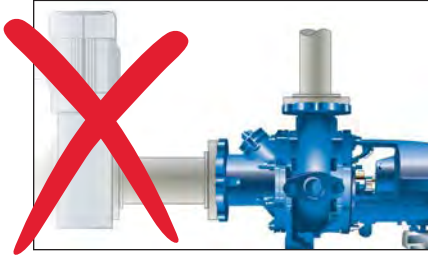

Hayward Gordon chopper pumps provide cutting and pumping action in a single unit. This can save the maintenance and capital costs (as well as space) associated with separate solids reduction equipment such as grinders and comminutors.

### 2. Solids Reduction and Blending

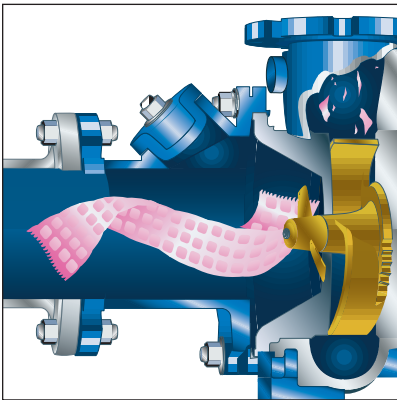

Prior to entering the casing, large solids are chopped and reduced in size to ensure passage through the pump without clogging. An optional disintegrator blade can be added at the inlet to break up large solids and facilitate entry into the suction for further cutting by the impeller.

### 3. Protection From Internal Binding and Fouling

After chopped solids enter the pump, they are prevented from binding the impeller or fouling the seal area by a secondary cutting and clearing action. The impeller's patented rear cutter features a sharpened and serrated rear shroud that sweeps over spiral grooves in the casing back plate. The interaction of the rear cutting shroud and grooves acts to cut and then expel stray material from behind the impeller.

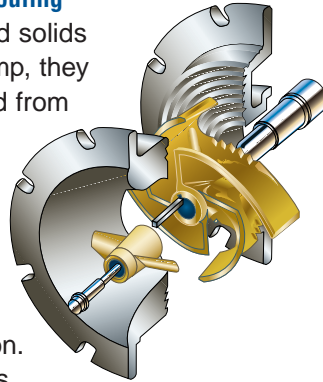

### 4. High Efficiency, Improved NPSH

Our patented, computer generated impeller blade profiles provide cutting action at the leading edge while ensuring a smooth flow path for the fluid along the rest of the vane. The smooth flow minimizes turbulence, thereby reducing power consumption and improving NPSH.

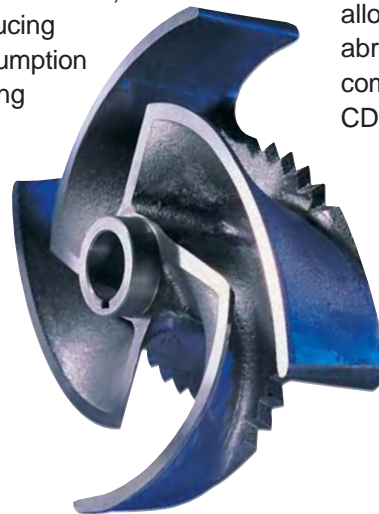

### 5. Abrasion Resistant Construction

Hayward Gordon's proven clamp-type construction eliminates the need for drilled and tapped holes on many wet end components. This allows construction in a variety of wear resistant metals including Ni-Hard, High Chrome Iron, and hardened alloy steel. To compensate for wear and to maximize component life, clearance between the intake cutting plate and impeller is externally adjustable.

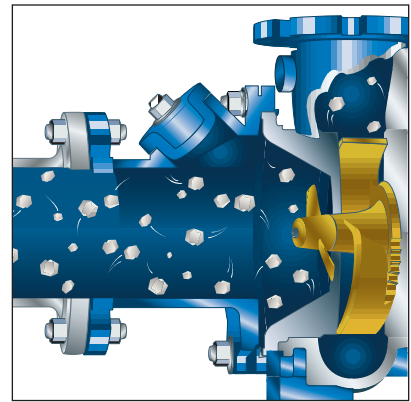

### 6. Corrosion Resistant Construction

Materials of construction available for the CHOPX pump include stainless steel and other corrosion resistant alloys. Where both corrosion and abrasion resistance is required components can be supplied in CD4MCu.





## HORIZONTAL CONFIGURATION - FEATURES

Hayward Gordon horizontal chopper pumps are built with all the heavy duty features common to our full line of solids handling pumps. Powerframes are back pullout for convenient servicing, and wet-ends are clamped to facilitate construction in ultra-hard metals. All shafts and bearings are sized to provide 100,000 hour B<sub>10</sub> life in either direct drive or v-belt configuration.

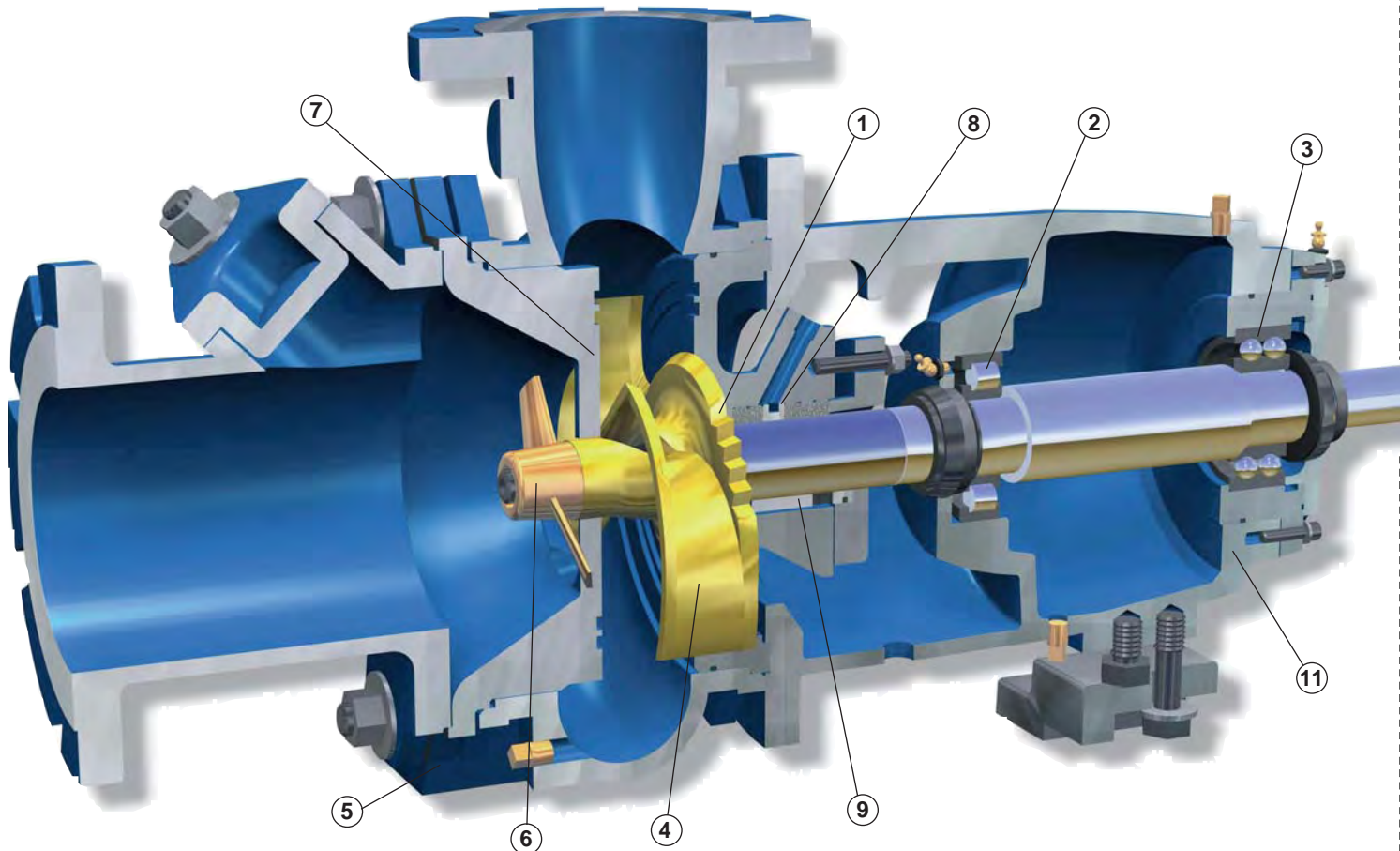

1. Sharpened and serrated patented rear cutter on impeller shroud sweeps over spiral grooves in the casing backplate to cut and then expel stray material from behind the impeller.
2. Cylindrical roller bearings to provide reliable operation under heavy radial loads.
3. Double row thrust bearings mounted in a separate housing for easy installation and external adjustment of impeller clearance.
4. Highly engineered and patented blade profiles provide cutting action at the leading edge while ensuring a smooth flow path for the fluid along the rest of the vane. The unique vane design reduces power consumption and improves NPSH.
5. Back pullout design with integrally cast casing feet, allows servicing of powerframe without disturbing suction or discharge piping.
6. Optional disintegrator tool breaks up large solids prior to entry into the pump.
7. Powerful cutting action achieved by hardened intake plate with profiled cutter bars acting against sharpened, rotating impeller blades.
8. Packed stuffing box option includes a split bronze gland for easy access and a hardened shaft sleeve for minimum maintenance.
9. Mechanical seal options specifically designed for handling tough solids.
10. Heavy duty shaft designed to withstand large radial loads at both ends – from the impeller and from v-belt drives.
11. Modular powerframe, 100% interchangeable with the XCS Series Screw Centrifugal Solids Handling Pumps, reduces spare parts inventories.

# VERTICAL CONFIGURATION - FEATURES

Hayward Gordon vertical sump chopper pumps are designed for reliable operation in heavy duty sump applications. To withstand the rigors of demanding chopping services, the shaft is supported along its entire length by anti-friction bearings lubricated in an oil bath formed by the pump column (a pump protection system shuts the pump down if the oil bath drops below required levels). The lower shaft section is supported by its own, independent powerframe to limit shaft deflection at the seal regardless of pump length.

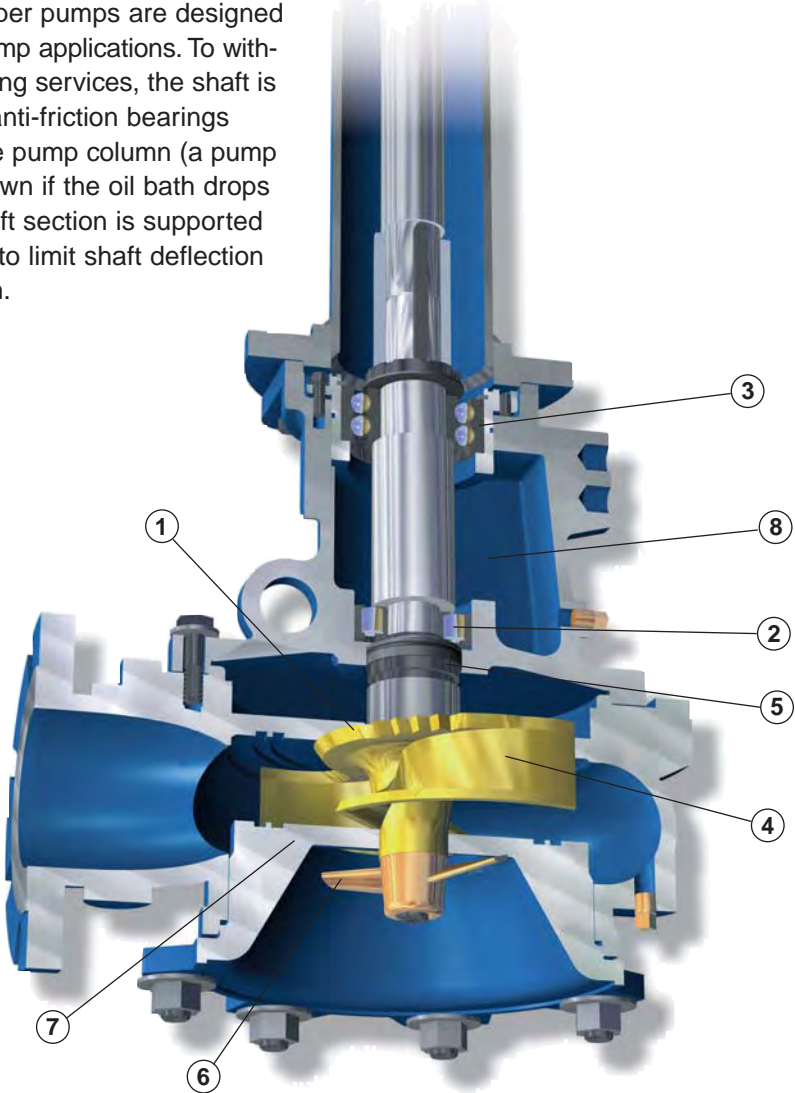
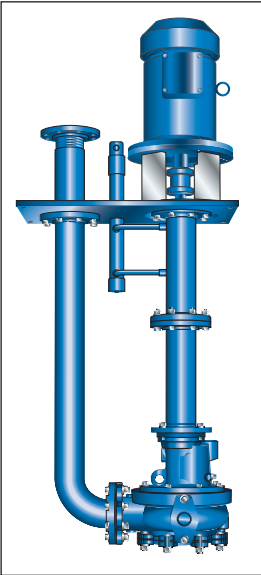

1. Sharpened and serrated patented rear cutter on impeller shroud sweeps over spiral grooves in the casing backplate to cut and then expel stray material from behind the impeller.
2. Cylindrical roller bearings to provide reliable operation under heavy radial loads.
3. Double row thrust bearings mounted in a separate housing for easy installation and adjustment of impeller clearance.
4. Highly engineered and patented blade profiles provide cutting action at the leading edge while ensuring a smooth flow path for the fluid along the rest of the vane. The unique vane design reduces power consumption and improves NPSH.
5. Hard faced mechanical seal specifically designed for handling tough solids. Seal is set screw driven, has no exposed springs to jam up, and features self-aligning faces.
6. Optional disintegrator tool breaks up large solids prior to entry into the pump.
7. Powerful cutting action achieved by hardened intake plate with profiled cutter bars acting against sharpened, rotating impeller blades.
8. Oil bath lubrication of bearings and mechanical seal.