

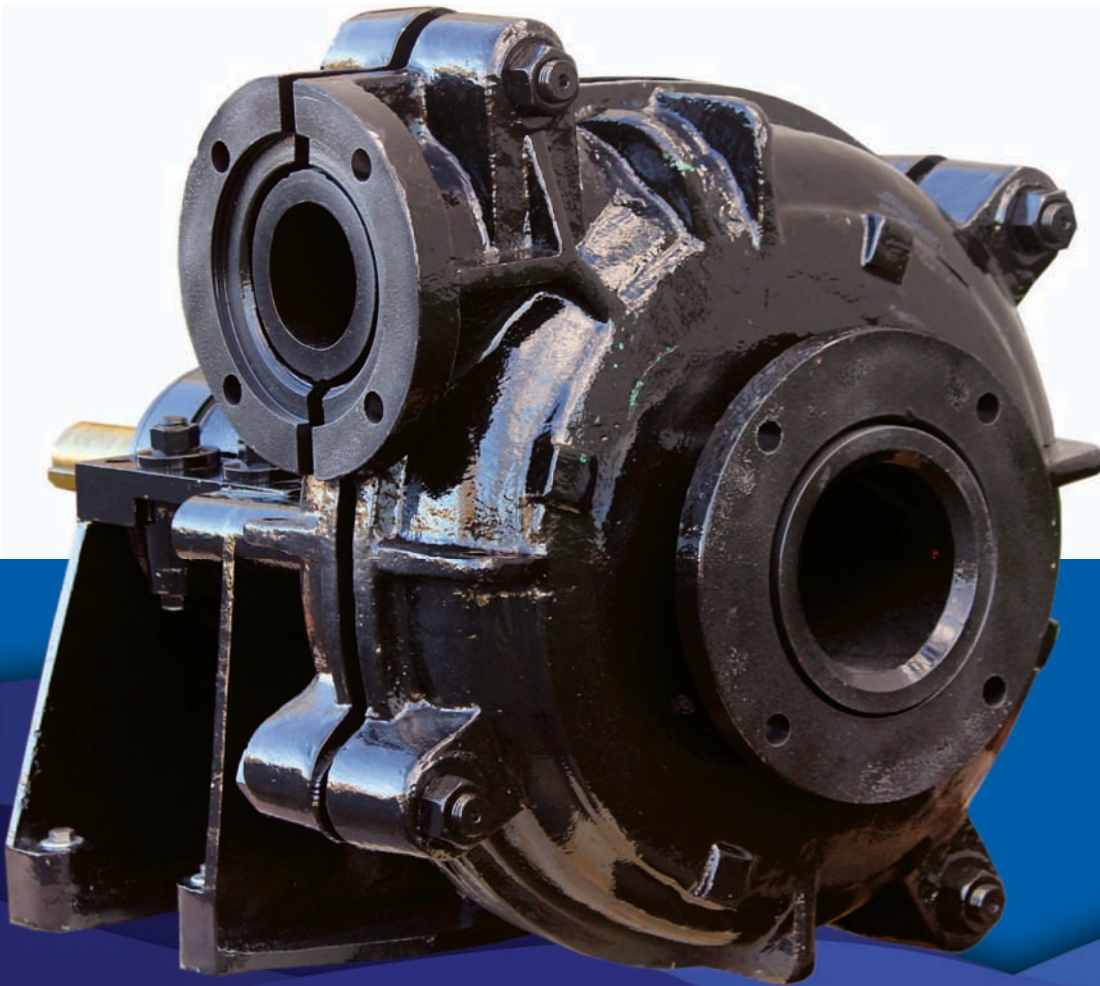

CORNELL PUMP COMPANY

SLURRY PUMPS



EFFICIENT BY DESIGN



SP SERIES SLURRY PUMPS



CORNELL'S NEW SLURRY PUMPS EXPANDS OUR LINE OF DEWATERING PUMPING SOLUTIONS TO ABRASIVE APPLICATIONS IN THE MINING PROCESS INDUSTRY. WITH CORNELL'S PATENTED CYCLOSEAL® TECHNOLOGY, OUR SLURRY PUMPS ARE BUILT FOR EXTENDED LIFE.

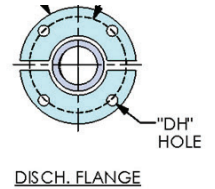
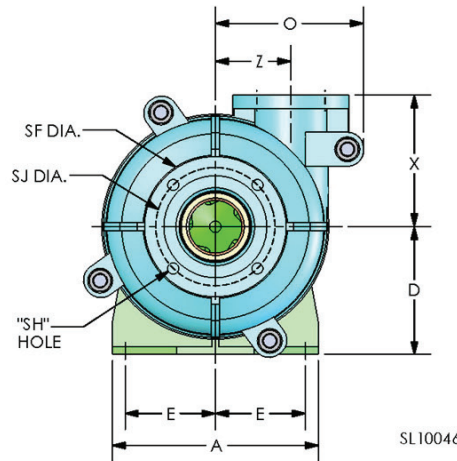
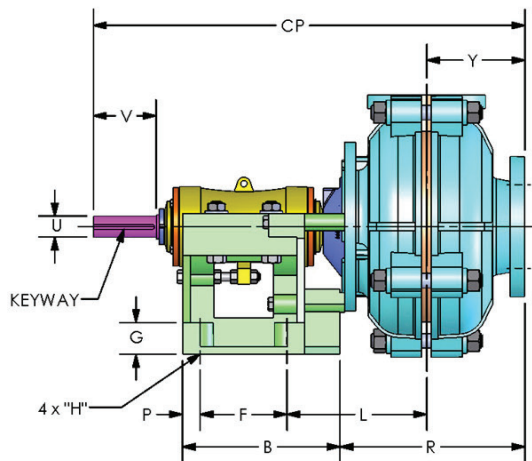

SL10046

FLANGE DIMENSION

WEIGHT	
MODEL	FRAME
2SP	C

APPLICATIONS

- Dewatering
- Cyclone feed
- Re grind
- Flotation
- Mill discharge
- Tailings and mine refuse
- Mining and mineral processing
- Heavy duty abrasive slurries
- Medium duty abrasive slurries
- In-plant slurry transfer pumps





SP SERIES SLURRY PUMPS

CYCLOSEAL®: THE INNOVATION THAT DISTINGUISHES THE SP SERIES AS CORNELL TOUGH

Cornell's Cycloseal® design, with its unique deflector vanes, works with the expeller to create a cyclo-action. This action removes solids and abrasive material from the seal area while purging air and gas pockets – extending seal life and eliminating any need for venting or water flush.

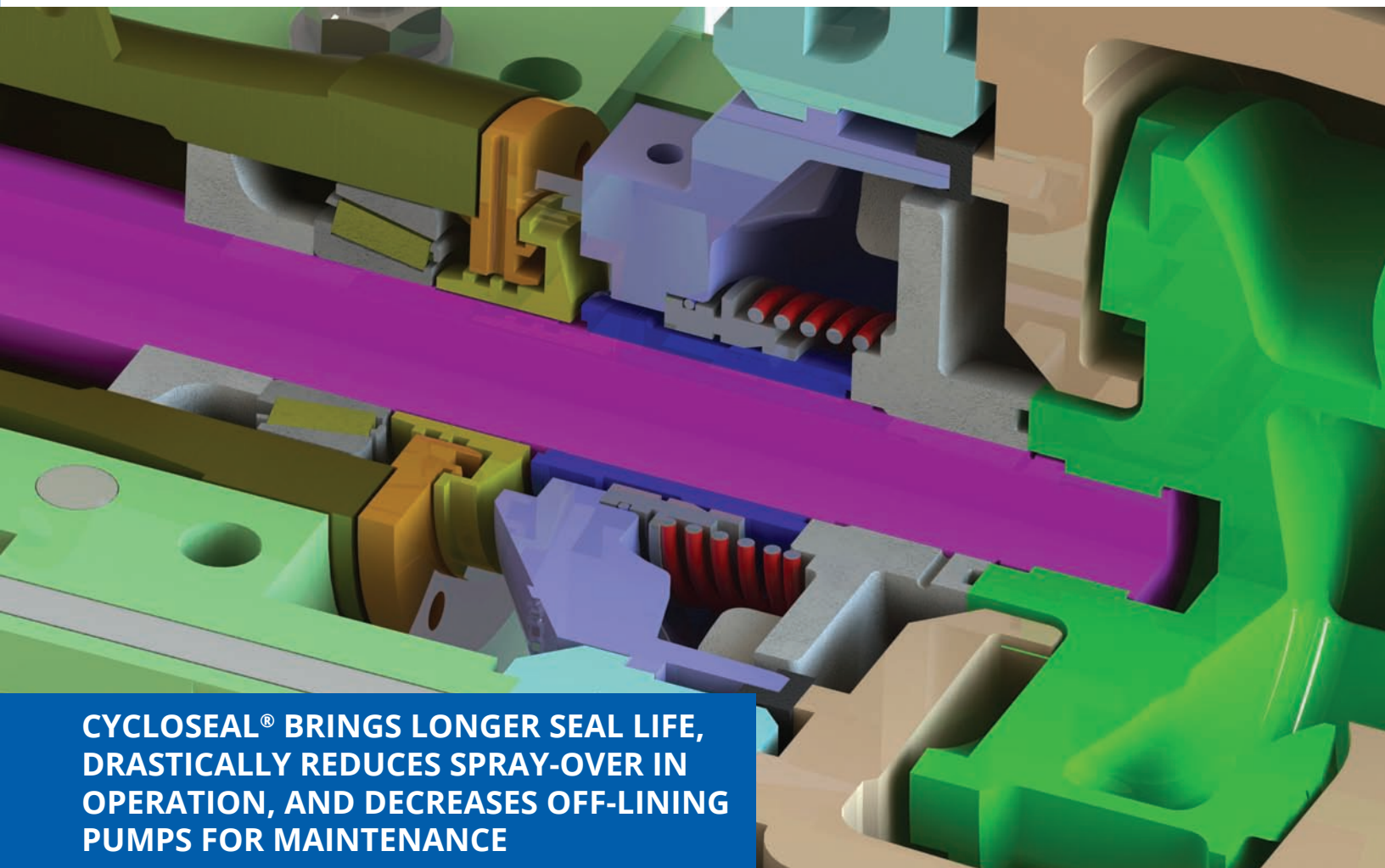

CYCLOSEAL® BRINGS LONGER SEAL LIFE, DRASTICALLY REDUCES SPRAY-OVER IN OPERATION, AND DECREASES OFF-LINING PUMPS FOR MAINTENANCE

CYCLOSEAL® BENEFITS:

Extended Seal Life: Cornell's Cycloseal® design has proven itself in the toughest applications from manure slurry to starch recovery to clear water, food processing, self-priming and hot cooking oil applications — in some cases more than tripling the normally expected mechanical seal life.

Run-Dry™ Option: All pumps equipped with Cornell's Cycloseal® system have an optional run-dry feature available, which serves to lubricate the seal faces even when there is no liquid in the pump casing. In situations where the pump must run dry for several hours, or where the pump may suddenly lose prime without being shut off, the Run-Dry™ feature is a must.

System Savings: The Cycloseal® system requires no external water flush, filters, grease cups, piping or instrumentation normally associated with packing or double mechanical seals.

Maintenance Savings: Longer seal life which translates into less pump down time and lower maintenance costs.

SP SERIES SLURRY PUMPS



SPECIFICATIONS

- Housing Material: Cast iron
- Liner Material: Chrome iron or rubber
- Impeller Material: Chrome iron or rubber
- Backplate: Chrome iron
- Bearing Housing & Pedestal: Cast iron
- Discharge Size: 2 inches to 12 inches
- Flow rate: Up to 14,000 GPM
- Seal Type: Cycloseal® or gland packing
- Solids Diameter: Up to 3.5 inches
- Impeller Type: Enclosed
- Head: Up to 210 feet

The SP Series is designed to transport strong abrasive slurry with high concentration of solids, at pH levels 5 of to 12. Pumps available in chrome iron and rubber configurations. SP series pumps are designed to handle abrasive high density slurries in mining, metallurgical, coal, manure, and other industrial applications.

BENEFITS

- Solids handling up to 3.5 inches
- Heads up to 210 feet
- Industry leading two year warranty
- Superior abrasive and corrosive wear life
- Handles pH levels of 5 to 12
- Available in rubber or chrome-iron configuration

FEATURES

- Specific lining allows for various material handling
- Large handling size means fewer clogged impellers
- Robust design allows it to be in difficult operating environments
- Seal lasts up to three times longer than other mechanical seals
- Patented Cycloseal® and Run-Dry™ options

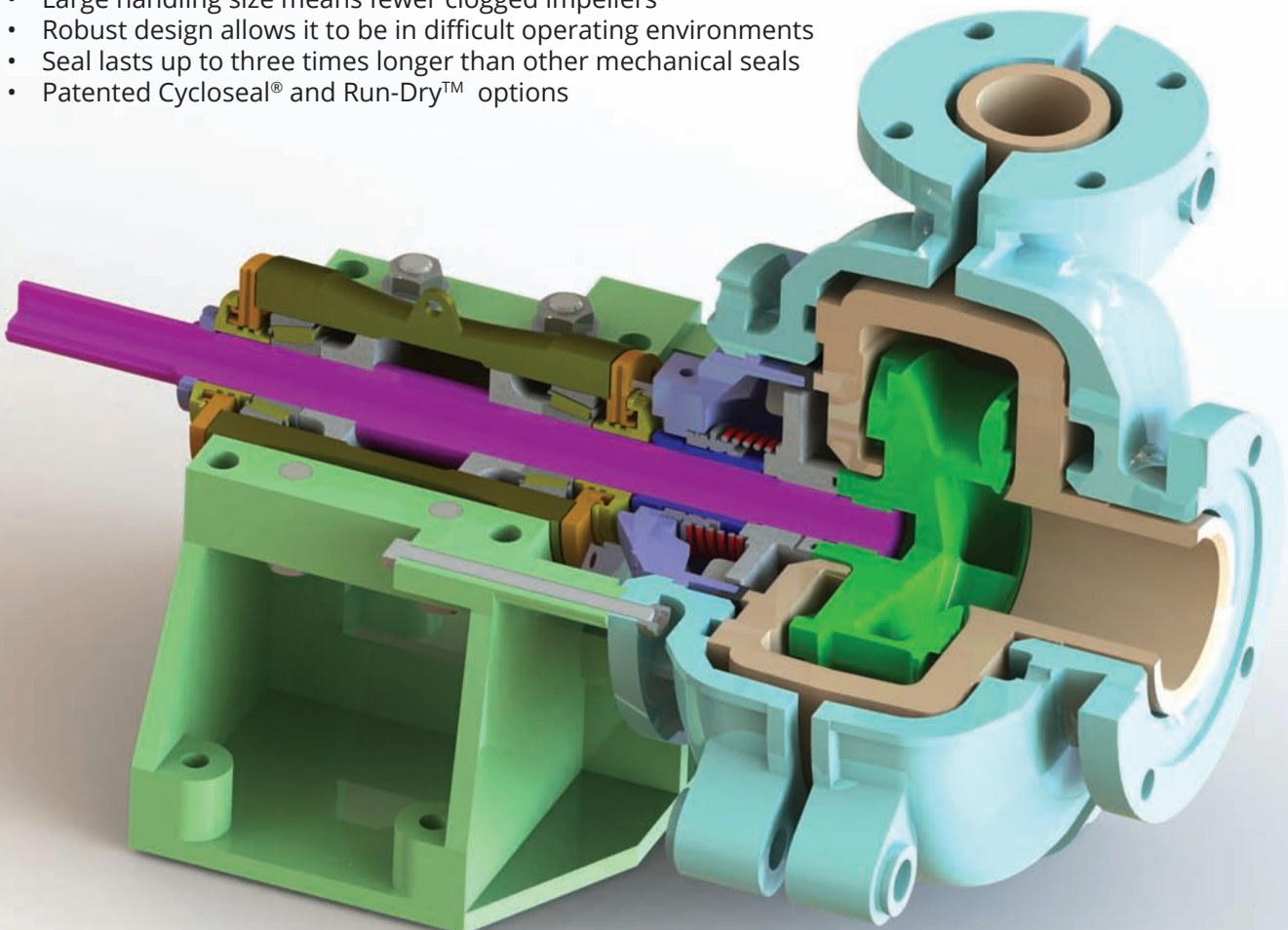



SP SERIES SLURRY PUMPS

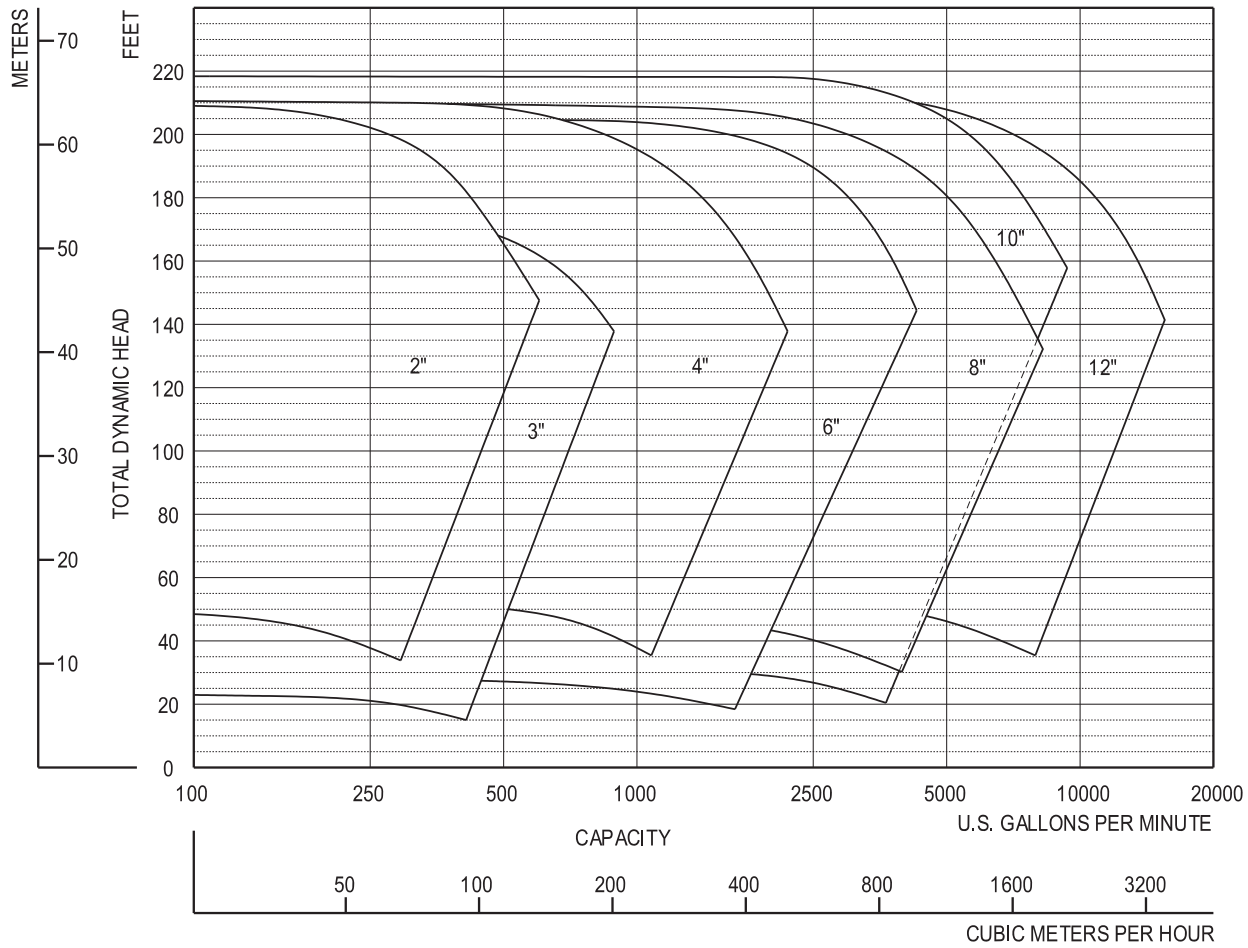

MODEL

- 2SP
- 3SP
- 4SP
- 6SP
- 8SP
- 10SP
- 12SP

NOTES:

1. Do not use for construction unless certified.
2. Dimension "U" and Keyway are in millimeters.
All other dimensions in inches.

MODEL	FLANGE DIMENSION					
	DISCHARGE			SUCTION		
	DF	DJ	DH	SF	SJ	SH
2SP	7.25	5.75	4x.75	8.5	7	4x.75
3SP	9.02	7.52	4x.88	10.98	9.25	4x.88
4SP	10.98	9.25	4x.88	13.27	11.5	4x.88
6SP	14.49	12.76	8x.81	15.98	14.02	8x.88
8SP	17.01	14.76	8x1.13	19.76	17.52	8x1.13
10SP	20.75	18.5	12x1.0	20.75	18.5	8x1.0
12SP	21.73	19.49	12x1.0	23.03	20.51	12x1.0

2SP	C	420	340
3SP	C	580	520
3SP	D	800	640
4SP	D	1380	1000
4SP	E	1600	1400
6SP	E	3250	2165
6SP	R	4050	2965
8SP	ST	8270	6900
10SP	ST	4520	7400
12SP	ST	14130	10300

PUMP DIMENSIONS

MODEL	FRAME	CONNECTION		A	B	CP	D	E	F	G	H	L	O	P	R	U	V	X	Y	Z	KEYWAY
		DISCH.	SUCT.																		
2SP	C	2	3	15.98	12.24	30.24	10	7	6.89	1.89	0.75	9.17	9.37	1.26	11.06	42mm	4.76	8.27	5.98	5.43	12mm x 8mm
3SP	C	3	4	15.98	12.24	33.19	10	7	6.89	1.89	0.75	10.63	11.5	1.26	13.94	42mm	4.76	10.31	7.4	5.87	12mm x 8mm
3SP	D	3	4	19.37	14.33	37.13	13	8.5	8.39	2.52	0.87	10.98	11.5	1.5	13.9	65mm	6.46	10.31	7.4	5.87	18mm x 11mm
4SP	D	4	6	19.37	14.33	40.2	13	8.5	8.39	2.52	0.87	12.52	15.98	1.5	16.57	65mm	6.46	13.31	8.5	9.02	18mm x 11mm
4SP	E	4	6	24.49	17.64	46.38	17.99	10.75	10.12	2.99	1.14	13.82	15.98	2.13	17.05	80mm	8.74	13.31	8.5	9.02	22mm x 14mm
6SP	E	6	8	24.49	17.64	51.26	17.99	10.75	10.12	2.99	1.14	15.83	21.69	2.13	21.93	80mm	8.74	18.11	11.5	12.52	22mm x 14mm
6SP	R	6	8	26.77	23.23	53.54	13.78	11.02	19.29	2.76	-	12.28	21.69	1.98	21.81	85mm	8.5	18.11	11.5	12.52	22mm x 14mm
8SP	ST	8	10	45.28	30.71	68.82	25.59	17.72	24.41	4.92	1.89	17.28	26.5	3.15	27.24	120mm	11.02	25	13.11	16.5	32mm x 18mm
10SP	ST	10	12	45.28	30.71	71.5	25.59	17.72	24.41	4.92	1.89	18.13	29.72	3.15	30	120mm	11.02	26.54	15	18.27	32mm x 18mm
12SP	ST	12	14	45.28	30.71	73.74	25.59	17.72	24.41	4.92	1.89	19.13	37.17	3.15	31.97	120mm	11.02	32.76	15.98	24.76	32mm x 18mm

OPTIONS & OTHER PRODUCTS

MX SERIES HIGH PRESSURE PUMPS

Pressures to 800 feet TDH and flows to 8000 GPM. Designed to handle high head applications while providing a long service life. The high head MX SERIES pumps have multi-vane, enclosed impellers designed for **INDUSTRY LEADING EFFICIENCY**. The MX SERIES pumps have extra heavy wall thickness, high quality construction, CA6NM impellers and are available in a horizontal frame & SAE mounted configurations.

- Discharge sizes: 2", 3", 4", 6" and 8" available
- 600 - 800ft. TDH flows to 8000 GPM
- CA6NM impellers
- Ductile Iron case
- Cornell Pump quality
- Industry leading efficiency
- 2 year warranty



MP SERIES MINING PUMPS DESIGNED FOR COARSE ABRASIVES

An adjunct to SP series, The MP series offers high operating pressures, the MP pumps are specifically designed for coarse abrasive slurry applications such as sand, gravel, coal, manure, and mine dewatering.

- Discharge Sizes: 4, 6, and 8 inches
- Flow Rates: Up to 9,000 GPM
- Heads: Up to 550 feet
- Solids Diameter: Up to 3 inches
- Seal Type: Cycloseal®
- Impeller type: Enclosed
- Available in horizontal frame and SAE mount configurations
- Heavy duty construction for aggressive applications.
- Hardness rating > 650BHN provides better wear properties compared to standard cast or ductile iron.

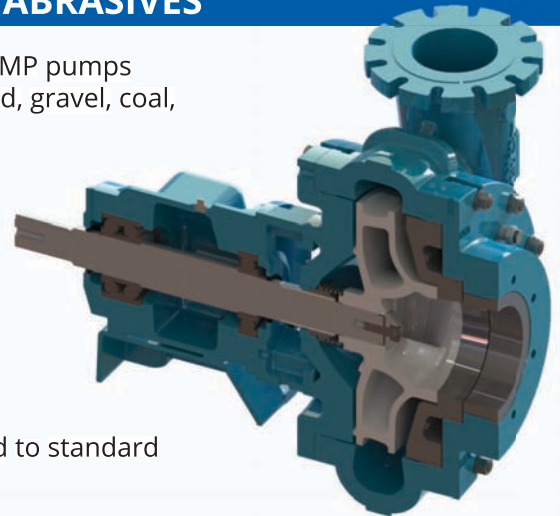

MINE DEWATERING

Specializing in high head dewatering pumps, Cornell has delivered dependable, reliable, and efficient pumps for decades. Our new innovative CD4 Duplex metal volutes, shafts, and impellers increase our solids handling capability. Our self-priming pumps coupled with our impressive suction of 28 feet and head of up to 800 feet make our pumps ideal suited to dewater the toughest mining applications. Our products are used successfully in long wall, traditional pier and beam, pit, and strip mining applications.



OPTIONS & OTHER PRODUCTS

WATER TRANSFER HYDRAULIC FRACTURING

Setting the standard for fracking, Cornell's pumps are designed and engineered for the most rugged and demanding installations. From the Antrim to Woodford Shales, Cornell pumps have exceed operating expectations, and provided hydraulic fracturing companies unprecedented uptime, reliability, and efficiency.

- Heads up to 800 feet
- Valve eliminates any liquid carry-over
- Suction lifts up to 28 feet
- Hardened Iron extends life of pump
- Fully automated priming and self-priming, dry-run pumps
- Handles Air/liquid mixtures with ease
- High suction lift capabilities up to 28 feet
- Up to 7000 GPM flow

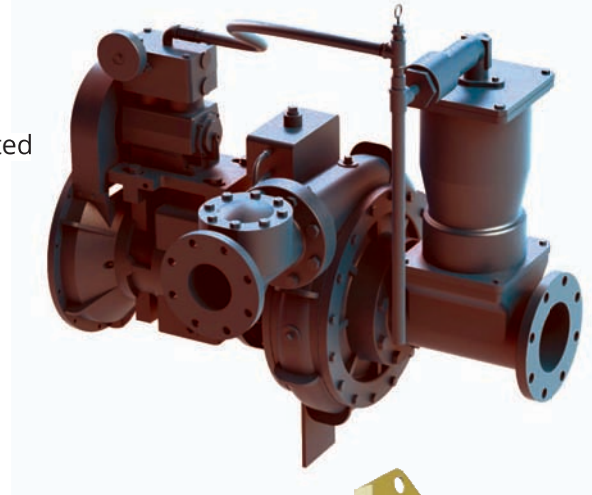

HYDRAULIC SUBMERSIBLE PUMPS

Cornell's DuraSub™ uses a heavy duty pump end and bearing frame for direct coupling to a hydraulic motor. The DuraSub™ has a modular design which allows standard Cornell pump ends to be used as a Hydraulic submersible pump.

- Available for most Cornell pump models
- Hydraulic motor driven
- Various adapter plates available for hydraulic motor fit
- Heavy duty shaft / bearing frame assembly and wet end construction
- Premium wet end efficiencies reduce horsepower requirements
- Heavy duty pumps ends for long service life and reliability



CLEAR LIQUID PUMP

Cornell Clear Liquid pumps are used for commercial and residential irrigation, golf course and lawn maintenance, aqua culture, fountains, breweries, laundries, cooling towers, fire fighting, reverse osmosis feed, and water boosters.

The W, Y, R and H series pumps are available in a wide range of materials with discharge sizes ranging from 1 to 10 inches, heads to 450 feet TDH, and flow rates up to 7,000 GPM.



REDI-PRIME®

Cornell Redi-Prime® pumps are designed with oversized suctions to provide more flow, reduced friction losses, and higher suction lift. The priming system was designed with the environment in mind. By using a positive sealing float box and a diaphragm vacuum pump, there is no water carry-over to contaminate the environment. With suction lifts of up to 28 feet, heads to 470 feet and flow rates exceeding 20,000 GPM, most Cornell pumps can be readily fitted with the Redi-Prime® system.

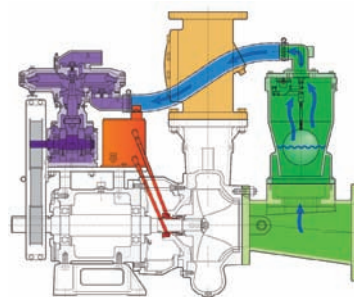



MARKET AND PRODUCT LINE



AGRICULTURAL



FOOD PROCESS



INDUSTRIAL

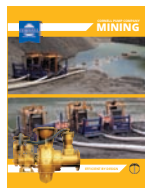

MINE DEWATERING



MUNICIPAL

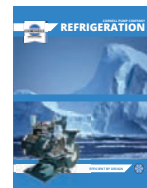

REFRIGERATION

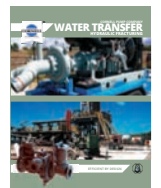

WATER TRANSFER



CHOPPER



CUTTER



EDGE™



HYDRAULIC SUBS



HYDRO TURBINE



IMMERSIBLE



MANURE



MP SERIES



MX SERIES



REDI-PRIME®



STX



SLURRY

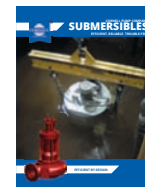

SUBMERSIBLE

Cycloseal®, and Redi-Prime® are Registered Trademarks of Cornell Pump Company.

Cornell pumps and products are the subject of one or more of the following U.S. and Foreign patents: 3,207,485; 3,282,226; 3,295,456; 3,301,191; 3,630,637; 3,663,117; 3,743,437; 4,335,886; 4,523,900; 5,489,187; 5,591,001; 6,074,554; 6,036,434; 6,079,958; 6,309,169; 2,320,742; 96/8140; 319,837; 918,534; 1,224,969; 2,232,735; 701,979 and are the subject of pending U.S. and Foreign Patent Applications.



Cornell Pump Company
 16261 SE 130th Ave
 Clackamas, OR 97015
 P: (503) 653-0330
 F: (503) 653-0338



CORNELLPUMP.COM
 ©2013 CORNELL PUMP COMPANY